

#hybrid stepper motor 17HS0401L1-18B

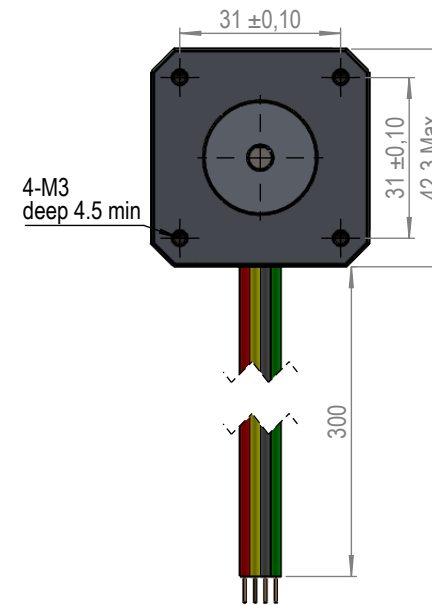

HYBRID STEPPER MOTOR SPECIFICATIONS

SPECIFICATIONS	COMMENTS	GEAR SPECIFICATIONS
Step Angle	1.8°±5%	
Number of Phase	2	
Rated Voltage	2.6 V	
Rated Current/Phase	0.8 A (Peak Value)	
Holding Torque	120 mH.m (motor)	
Detent Torque	3 mH.m	
Phase Resistance	3.3 Ω±10%	
Phase Inductance	3 mH±20%	
Dielectric Strength	AC 500V/ 1min / 5mA Max.	
Rotor Inertia	15 g-cm ²	
Weight	200 g	
Insulation Class	Class B	

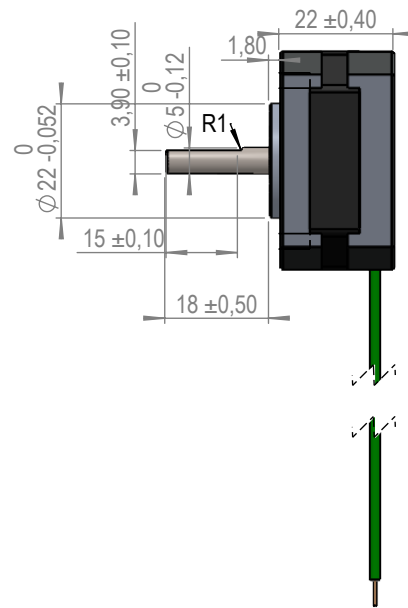

NAME Nema17 Pancake Stepper 22mm
 TYPE Hybrid Stepper Motor
 SKU 13002A